

Data Sheet

SonoMeter 30

Energy Meters

Description



The Danfoss SonoMeter 30 is a range of ultrasonic, compact energy meters intended for measuring energy consumption in heating and cooling applications for billing purposes. The meters are designed for remote meter read-out (AMR).

SonoMeter 30 energy meters consist of an ultrasonic flow sensor, a pair of Pt500 temperature sensors and a calculator with integrated circuits for temperature measurement, flow calculation and energy calculation.

Features

- Available in nominal flow rates qp 0.6, 1.5, 2.5, 3.5, 6.0, 10.0 and 15.0 m³/h
- Housings with thread (G3/4 to G2) or flange (DN20 to DN50) connections
- MID approval for ultrasonic energy meter with dynamic range of 1:100 (qi:qp) in class 2
- Optional MID approved dynamic range of 1:250 in class 2 for qp 1.5, 2.5, 6.0, 10 and 15 m³/h
- Temperature range 5 - 130° C, PN 16 or 25 bar
- Short overload temperature up to 150° C
- Glycol mixtures as option (not MID certified)
- Calculator with IP65 protection class as standard
- Flow sensor with IP65 protection class as standard (IP67 for combine heating and cooling applications)
- Return or supply pipe installation, for vertical or horizontal mounting
- Battery lifetime for at least 11 years
- Low pressure loss, insensitive to dirt
- No calming sections needed before or after the flow sensor
- Remote reading via M-Bus, radio OMS 868 MHz, RS-485 Modbus RTU, pulse output or optical interface
- Two pulse inputs or outputs (selectable) as standard

Ordering

Energy meter application	Nominal flow, size and connection type	Comm. module	Energy unit	Installation	Temp. sensors length	Flow cable length ¹⁾	Operating pressure	Code no.
Heating	DN 15 / G¾B / qp 0.6 m³/h / 110 mm thread	M-Bus	kWh	Return	1.5 m	1.2 m	16 bar	187F3001
Heating	DN 15 / G¾B / qp 0.6 m³/h / 110 mm thread	OMS 868.95	kWh	Return	1.5 m	1.2 m	16 bar	187F3002
Heating / cooling	DN 15 / G¾B / qp 0.6 m³/h / 110 mm thread	M-Bus	kWh	Return	1.5 m	1.2 m	16 bar	187F3008
Heating / cooling	DN 15 / G¾B / qp 0.6 m³/h / 110 mm thread	OMS 868.95	kWh	Return	1.5 m	1.2 m	16 bar	187F3009
Heating	DN 15 / G¾B / qp 1.5 m³/h / 110 mm thread	M-Bus	kWh	Return	1.5 m	1.2 m	16 bar	187F3015
Heating	DN 15 / G¾B / qp 1.5 m³/h / 110 mm thread	OMS 868.95	kWh	Return	1.5 m	1.2 m	16 bar	187F3016
Heating / cooling	DN 15 / G¾B / qp 1.5 m³/h / 110 mm thread	M-Bus	kWh	Return	1.5 m	1.2 m	16 bar	187F3022
Heating / cooling	DN 15 / G¾B / qp 1.5 m³/h / 110 mm thread	OMS 868.95	kWh	Return	1.5 m	1.2 m	16 bar	187F3023
Heating	DN 20 / G1B / qp 1.5 m³/h / 130 mm thread	M-Bus	kWh	Return	1.5 m	1.2 m	16 bar	187F3130
Heating	DN 20 / G1B / qp 1.5 m³/h / 130 mm thread	OMS 868.95	kWh	Return	1.5 m	1.2 m	16 bar	187F3131
Heating / cooling	DN 20 / G1B / qp 1.5 m³/h / 130 mm thread	M-Bus	kWh	Return	1.5 m	1.2 m	16 bar	187F3134
Heating / cooling	DN 20 / G1B / qp 1.5 m³/h / 130 mm thread	OMS 868.95	kWh	Return	1.5 m	1.2 m	16 bar	187F3135
Heating	DN 20 / G1B / qp 2.5 m³/h / 130 mm thread	M-Bus	kWh	Return	1.5 m	1.2 m	16 bar	187F3029
Heating	DN 20 / G1B / qp 2.5 m³/h / 130 mm thread	OMS 868.95	kWh	Return	1.5 m	1.2 m	16 bar	187F3030
Heating / cooling	DN 20 / G1B / qp 2.5 m³/h / 130 mm thread	M-Bus	kWh	Return	1.5 m	1.2 m	16 bar	187F3036
Heating / cooling	DN 20 / G1B / qp 2.5 m³/h / 130 mm thread	OMS 868.95	kWh	Return	1.5 m	1.2 m	16 bar	187F3037
Heating	DN 25 / G1¼B / qp 3.5 m³/h / 260 mm thread	M-Bus	kWh	Return	2.0 m	1.2 m	16 bar	187F3043
Heating	DN 25 / G1¼B / qp 3.5 m³/h / 260 mm thread	OMS 868.95	kWh	Return	2.0 m	1.2 m	16 bar	187F3044
Heating / cooling	DN 25 / G1¼B / qp 3.5 m³/h / 260 mm thread	M-Bus	kWh	Return	2.0 m	1.2 m	16 bar	187F3050
Heating / cooling	DN 25 / G1¼B / qp 3.5 m³/h / 260 mm thread	OMS 868.95	kWh	Return	2.0 m	1.2 m	16 bar	187F3051
Heating	DN 25 / G1¼B / qp 6 m³/h / 260 mm thread	M-Bus	kWh	Return	2.0 m	1.2 m	16 bar	187F3057
Heating	DN 25 / G1¼B / qp 6 m³/h / 260 mm thread	OMS 868.95	kWh	Return	2.0 m	1.2 m	16 bar	187F3058
Heating / cooling	DN 25 / G1¼B / qp 6 m³/h / 260 mm thread	M-Bus	kWh	Return	2.0 m	1.2 m	16 bar	187F3064
Heating / cooling	DN 25 / G1¼B / qp 6 m³/h / 260 mm thread	OMS 868.95	kWh	Return	2.0 m	1.2 m	16 bar	187F3065
Heating	DN 40 / G2B / qp 10 m³/h / 300 mm thread	M-Bus	kWh	Return	2.0 m	2.5 m	25 bar	187F3071
Heating	DN 40 / G2B / qp 10 m³/h / 300 mm thread	OMS 868.95	kWh	Return	2.0 m	2.5 m	25 bar	187F3072
Heating / cooling	DN 40 / G2B / qp 10 m³/h / 300 mm thread	M-Bus	kWh	Return	2.0 m	2.5 m	25 bar	187F3078
Heating / cooling	DN 40 / G2B / qp 10 m³/h / 300 mm thread	OMS 868.95	kWh	Return	2.0 m	2.5 m	25 bar	187F3079
Heating	DN 40 / qp 10 m³/h / 300 mm flange	M-Bus	kWh	Return	2.0 m	2.5 m	25 bar	187F3085
Heating	DN 40 / qp 10 m³/h / 300 mm flange	OMS 868.95	kWh	Return	2.0 m	2.5 m	25 bar	187F3086
Heating / cooling	DN 40 / qp 10 m³/h / 300 mm flange	M-Bus	kWh	Return	2.0 m	2.5 m	25 bar	187F3092
Heating / cooling	DN 40 / qp 10 m³/h / 300 mm flange	OMS 868.95	kWh	Return	2.0 m	2.5 m	25 bar	187F3093
Heating	DN 50 / qp 15 m³/h / 270 mm flange	M-Bus	kWh	Return	2.0 m	2.5 m	25 bar	187F3099
Heating	DN 50 / qp 15 m³/h / 270 mm flange	OMS 868.95	kWh	Return	2.0 m	2.5 m	25 bar	187F3100
Heating / cooling	DN 50 / qp 15 m³/h / 270 mm flange	M-Bus	kWh	Return	2.0 m	2.5 m	25 bar	187F3106
Heating / cooling	DN 50 / qp 15 m³/h / 270 mm flange	OMS 868.95	kWh	Return	2.0 m	2.5 m	25 bar	187F3107

¹⁾ Cable length between flow sensor and energy calculator.

DN15 and DN 20 meters with thread has one temperature sensor mounted in the body.
 All above codes are battery powered meters with two 3.6 V AA cell batteries (lifetime min 11 years).
 More standard codes are available with mains power supply 230 V AC (with external transformer and one AA cell battery back-up).

Accessories

Product	Designation	Quantity	Code no.
Optical head	Optical head	1 pc.	187F3112
Power supply	Battery 3.6 V DC (AA cell)	1 pc.	187F3113
Power supply	Mains unit 230 V AC (external module)	1 pc.	187F3114
Power supply	Mains unit 24 V AC	1 pc.	187F3115
Communication module	M-Bus module	1 pc.	187F3116
Communication module	Radio OMS 868.95 MHz	1 pc.	187F3117
Communication module	RS-485 Modbus	1 pc.	187F3118
Temperature sensor	Pt 500 / f 5.2 mm / 1.5 m cable, MID	1 pc.	187F3125
Temperature sensor	Pt 500 / f 5.2 mm / 2 m cable, MID	1 pc.	187F3126
Temperature sensor	Pt 500 / f 5.2 mm / 3 m cable, MID	1 pc.	187F3127
Sensor pockets	Ø 5.2 mm, brass, 35 mm length	1 pair	087G6053
Sensor pockets	Ø 5.2 mm, brass, 52 mm length	1 pair	087G6054
Sensor pockets	Ø 5.2 mm, brass, 85 mm length	1 pair	087G6055
Sensor pockets	Ø 5.2 mm, brass, 120 mm length	1 pair	087G6056

Sensor pockets	Ø 5.2 mm, stainless steel, 85 mm length	1 pair	087G6057
Sensor pockets	Ø 5.2 mm, stainless steel, 120 mm length	1 pair	087G6058
Tail piece set	DN15 R $\frac{1}{2}$ x G $\frac{1}{4}$	1 set	087G6071
Tail piece set	DN20 R $\frac{3}{4}$ x G1	1 set	087G6072
Tail piece set	DN25 R1 x G1 $\frac{1}{4}$	1 set	087G6073
Adapter for temperature sensor	R $\frac{1}{2}$ x M10 x 1	1 pc.	087G6075
Adapter for temperature sensor	R $\frac{1}{2}$ x M10 x 1	32 pcs.	087G6076
Ball valve	G $\frac{1}{2}$ " internal thread, Pt sensor connection M10	1 pc.	187F0593
Ball valve	G $\frac{1}{2}$ " internal thread, Pt sensor connection M10	12 pcs.	087H0118
Ball valve	G $\frac{3}{4}$ " internal thread, Pt sensor connection M10	1 pc.	187F0592
Ball valve	G $\frac{3}{4}$ " internal thread, Pt sensor connection M10	12 pcs.	087H0119
Ball valve	G1" internal thread, Pt sensor connection M10	1 pc.	187F0591
Ball valve	G1" internal thread, Pt sensor connection M10	12 pcs.	087H0120

Technical specifications

Diameter	DN15			DN20			DN25			DN40			DN50											
Connection type	G $\frac{3}{4}$ B	G1B	FL	G $\frac{3}{4}$ B	G1B	FL	G1B	G1B	G1B	FL	G1 $\frac{1}{4}$ B	FL	G1 $\frac{1}{4}$ B	FL	G2B	FL	FL							
Overall length, mm	110	190			110	190			130	190			260			260			300	270				
Flow rate:																								
• Nominal, m ³ /h	0.6			1.5			2.5			3.5			6			10			15					
• Maximum, m ³ /h	1.2			3			5			7			12			20			30					
• Standard min., l/h	6			15			25			35			60			100			150					
• Extended min., l/h	-			6			-			10			-			24			40			60		
• Starting flow rate, l/h	3			3			5			5			17			12			20			30		
Max. operating pressure	16 bar												25 bar											
Flow sensor temp. range	5 to 130° C (short overload to 150° C)																							
Flow sensor cable length	1.2 m												2.5 m											
Medium	Water quality with pH 7 to 9.5																							
Pressure loss at q _p , mbar	70	9	171	58	72	198	94	40	100	180	120													
Measuring cycles	Volume every 1 sec., energy, temperature sensors and display update every 16 sec.																							
Temperature sensors	Pt 500 Ø 5.2 mm with 2-wire leads																							
Temp. sensor cable length	1.5 m						2.0 m																	
Max. temp. diff. (Δθ _{max})	150 K																							
Min. temp. diff. (Δθ _{min})	3.0 K																							
Starting temp. diff. (Δθ)	0.15 K																							
Temp. measuring range	0 to 180° C																							
Supply voltage	3.6 V DC Lithium-battery (AA cell) / Mains supply 24 V AC/DC. Mains supply 230 V AC (with external 230 V AC to 24 V AC transformer).																							
Battery life time	min. 11 years (including AMR communication)																							
Approval	EN1434 class 2																							
Environmental class	EN1434 class C																							
Ambient class	class E2 + M1																							
Protection class	Calculator: IP 65; Flow sensor: IP 65 (IP67 for heat and cooling meter)																							
Ambient operating temp.	Calculator: 5 to 55° C; Flow sensor: -30 to 55° C																							
Ambient storage and transportation temp.	5 to 55° C																							
Max. ambient humidity	93% rel. humidity																							
Display	LCD, 8-digit																							
Display units	MWh - kWh - GJ - Gcal - °C - m ³ - m ³ /h																							
Display values	Energy - volume - flow rate - power - temperatures																							

Application drawings

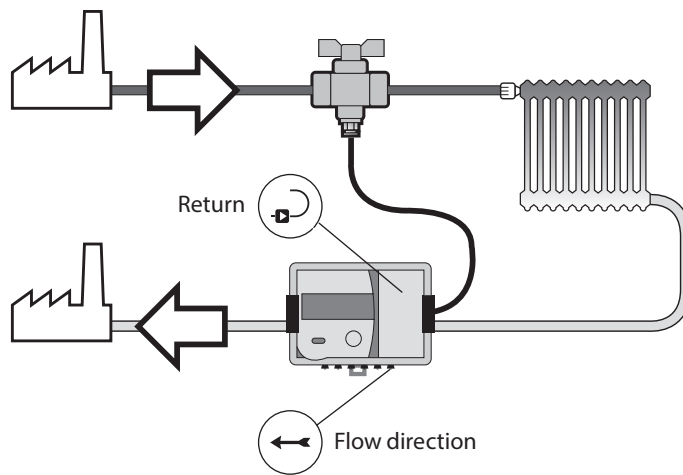

Return pipe installation

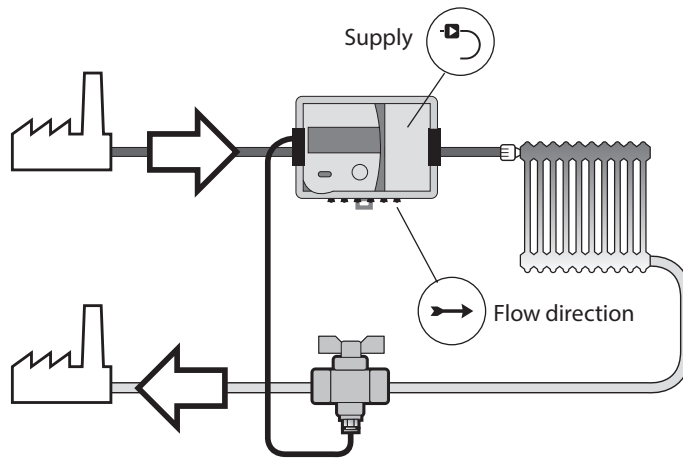

Supply pipe installation

Accuracy

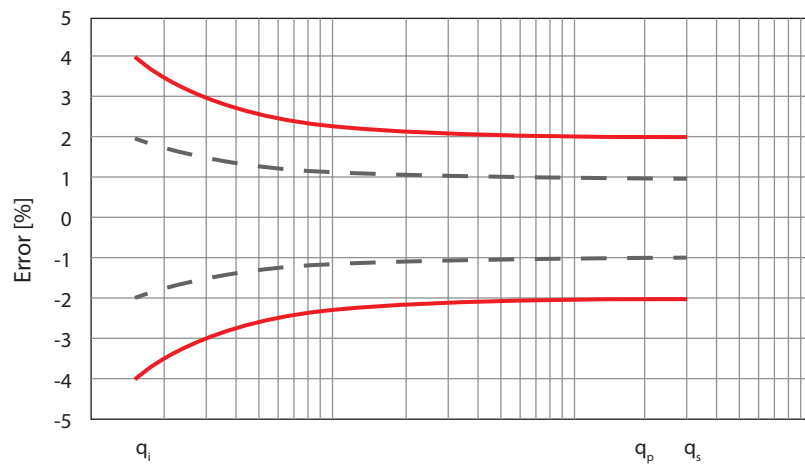

Measuring accuracy class 2

Pressure loss

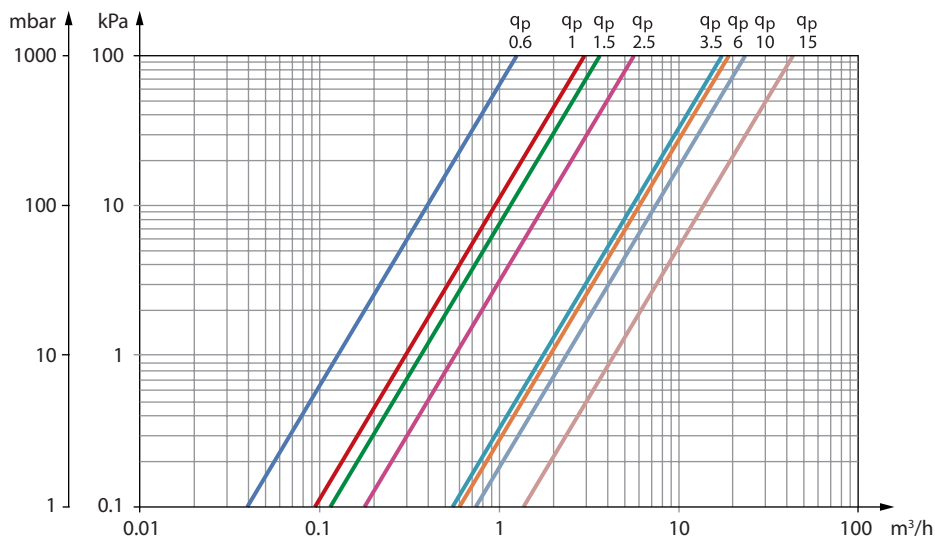

Design and function

Optical interface

Optical interface is integrated into the front panel of the calculator. It is designed for data reading via M-bus protocol and parameterization of the meter using SonoMeter 30 UserConfig software and optical head OG-1-USB.

The optical interface is activated by pressing the control button and shuts automatically off 5 minutes after the last pressing button or after completing data transmission via interface.

Wired M-Bus interface

The energy meter has 1 slot for an additional communication module. The internal M-Bus module provides data reading possibility via M-Bus protocol:

- M-Bus protocol according to EN13757-3 standard
- 2-wire with polarity reversal protection
- Electrical isolation
- Maximum voltage 50 V DC
- Current drawn: one M-Bus load (1.5 mA)
- Primary or secondary addressing
- Baud rate 300/1200/2400/4800/9600 (default: 2400 baud rate)
- Battery lifetime min. 11 years (2 AA cell)
- Fastest reading interval at battery supply: every 90 seconds (at 9600 bps, internally protected)
- Fastest reading interval at mains supply: no limits (auto at order or manual if added later)

Radio OMS 868.95 MHz interface

The module can provide data reading via radio module:

- Wireless M-Bus protocol according to EN13757-4
- OMS (open metering system) compatible
- T1 mode (unidirectional)
- Sending interval every 90 seconds (suitable for 'walk by' readings)

Modbus RS-485 module

RS-485 module is Modbus RTU protocol and a serial interface for communication with external devices.

Baud rate	1200, 2400, 4800, 9600(default), 38400, 56000, 57600, 115200
Power supply	Polarity independent connection for power supply – connectors 60 and 61. Voltage 12-24 V AC/DC. Maximum power consumption 2 W max. Typical supply current 50 mA.

2 pulse inputs or 2 pulse outputs (set up by jumpers)

There is a connector J on the calculator plate between the temperature sensors and pulse input / output connection terminals. By means of connecting or opening the connector contacts, the pulse inputs or outputs are activated.

Note: On delivery the heat meter is configured with two outputs.

Pulse inputs (not default, jumper set needed)

Number of pulse inputs	2
Measurement units	m ³ (51, 52), kWh (52, 53) or MWh, GJ, GCal
Pulse value	programmable by SonoMeter 30 UserConfig Software
Min. pulse time	100 ms
Pulse type	IB by LST EN1434-2
Max. frequency of input pulses	3 Hz
Max. voltage of input pulses	3.6 V
Condition of maintenance of high level	3.6 V via 3.3 MΩ resistor

Pulse outputs (default, no jumper set)

Number of pulse outputs	2
Measurement units	m ³ (51, 52), kWh (52, 53) or MWh, GJ, GCal,
Pulse value	according to the table below
Pulse type	open collector, permissible current up to 20 mA, voltage up to 50 V
Max. frequency of output pulses	4 Hz
Pulse duration	100 ms in normal mode, 1.6 ms in the test mode

Energy pulse output values (V1)

Energy units	kWh or MWh	GJ	Gcal
Pulse value of thermal energy	1 kWh/pulse	0.005 GJ/pulse	0.001 Gcal/pulse

Volume pulse output values (V2)

Nominal flow rate (qp), m ³ /h	0.6 - 6	10; 15
Pulse value, l/pulse	1	10

Data logger

Data logger

Following hourly, daily and monthly parameter values are recorded in energy meter memory (can be configured by SonoMeter 30 UserConfig software):

- 1..... Integrated heating energy
- 2..... Integrated cooling energy
- 3..... Integrated energy of tariff 1
- 4..... Integrated energy of tariff 2
- 5..... Integrated volume of liquid
- 6..... Integrated pulse value in pulse input 1
- 7..... Integrated pulse value in pulse input 2
- 8..... Maximum thermal power value for heating and date
- 9..... Maximum thermal power value for cooling and date
- 10.... Maximum flow rate value and date
- 11.... Maximum value of flow temperature of heat conveying liquid and date
- 12.... Maximum value of return temperature of heat conveying liquid and date
- 13.... Minimum value of flow temperature of heat conveying liquid and date
- 14.... Minimum value of return temperature of heat conveying liquid and date
- 15.... Minimum value of temperature difference and date
- 16.... Average value of flow temperature of heat conveying liquid
- 17.... Average value of return temperature of heat conveying liquid
- 18.... Operating time without an error of thermal energy calculation
- 19.... Total error code
- 20.... Time when the flow rate exceeded 1.2 q_s
- 21.... Time when the flow rate was less than q_i

Data logger capacity

- up to 1480 h – for hourly records
- up to 1130 days - for daily records
- up to 36 last months - for monthly records
- Storage time of measured integrated parameters even if device is disconnected from power supply: not less than 15 years

All data from archive can be read by means of the remote reading. In addition data logger records of monthly parameters can be seen on the display.

Power supply

Power supply (one of following depending on meter configuration):

- 2 AA cell battery 3.6 V DC, 2.4 Ah (Li-SOCI₂) lithium battery, life time at least 11 years
- Mains power supply 12 V AC to 36 V AC (50/60 Hz) or 12 V DC to 42 V DC:
 - The mains power supply 24V AC/DC module is mounted inside in the meter
 - Consumption is max 20 mA
 - Galvanically isolated + internal backup battery size AA cell, 3.6 V, 2.4 Ah, lithium battery (Li-SOCI₂). When the external power supply is turned off, the battery life time is not less than 11 years (without data reading via a digital interface)
- Mains power supply 230 V AC (+10% / -30%) 50/60Hz:
 - The meter should be equipped with an internal power supply unit and an external transformer. The 230 V AC to 24 V AC transformer is used for connection to mains power supply 24 V AC/DC module inside the meter
 - Consumption is max 10 mA

Menu structure

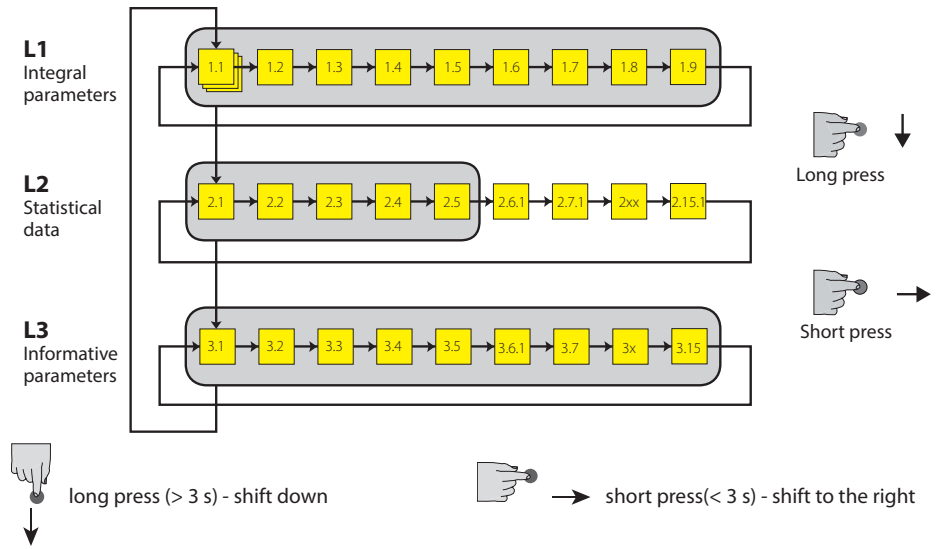

Mounting

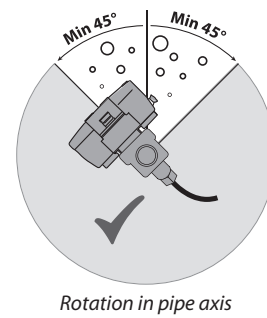
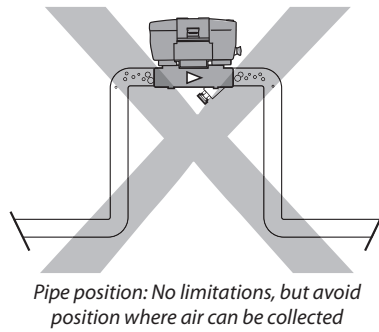

**Dimensions,
DN15, DN20 thread**

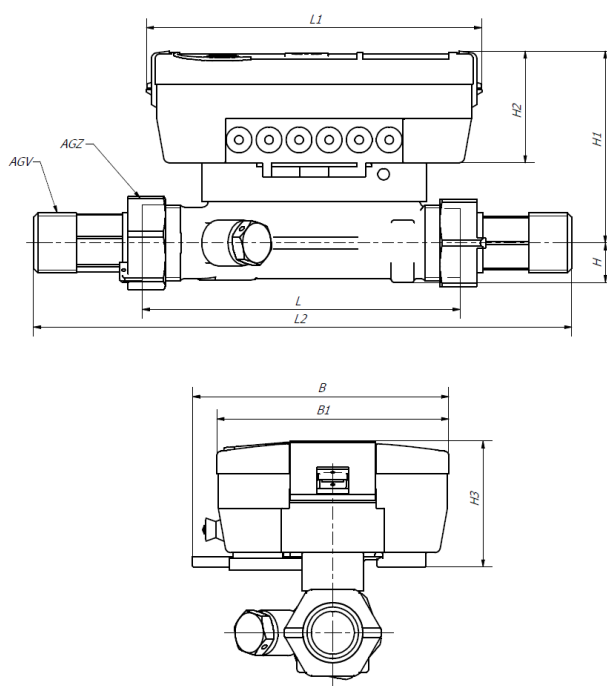

Nominal flow rate	q _p	m ³ /h	0.6/1/1.5	1.5 / 2.5	0.6/1/1.5/2.5
Nominal diameter	DN	mm	15	20	20
Overall length	L	mm	110	130	190
Overall length with coupling	L2	mm	185	224	284
Length of calculator	L1	mm	117	117	117
Height	H	mm	14	18	18
Height	H1	mm	67	67	68
Height of calculator	H2	mm	39	39	39
Height of calculator	H3	mm	44	44	44
Width	B	mm	90	90	90
Width of calculator	B1	mm	81	81	81
Connection thread of meter	AGZ	Inch	G ³ / ₄ B	G1B	G1B
Connection thread of coupling	AGV	Inch	G ¹ / ₂ B	G ³ / ₄ B	G ³ / ₄ B
Weight		kg	0.8	0.9	1.0

**Dimensions,
DN25 thread**

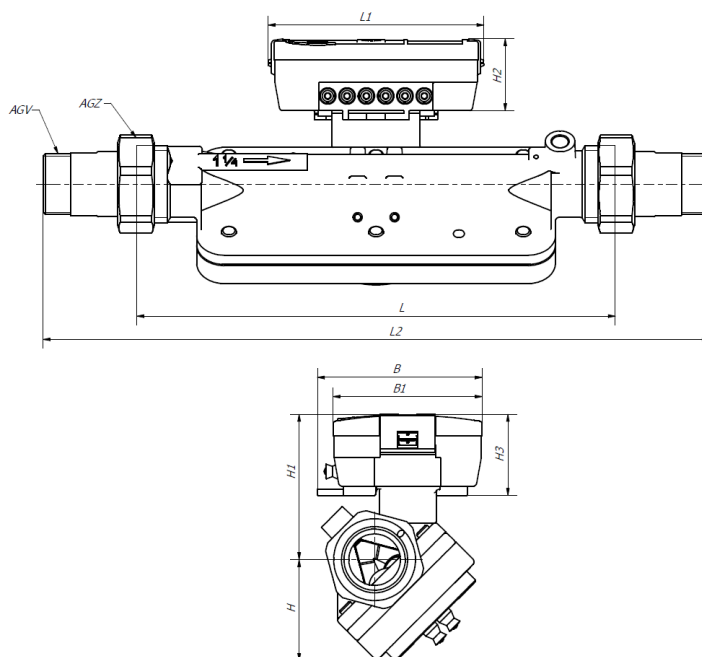

Nominal flow rate	q _p	m ³ /h	3.5/6
Nominal diameter	DN	mm	25
Overall length	L	mm	260
Overall length with coupling	L2	mm	360
Length of calculator	L1	mm	117
Height	H	mm	55
Height	H1	mm	79
Height of calculator	H2	mm	39
Height of calculator	H3	mm	44
Width	B	mm	90
Width of calculator	B1	mm	81
Connection thread of meter	AGZ	Inch	G1¼B
Connection thread of coupling	AGV	Inch	G1B
Weight		kg	3.6

**Dimensions,
DN40 thread**

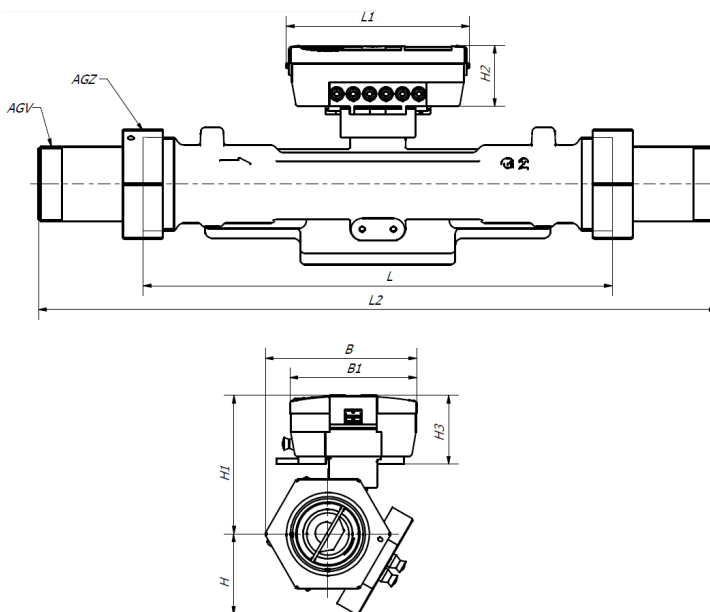

Nominal flow rate	q _p	m ³ /h	10
Nominal diameter	DN	mm	40
Overall length	L	mm	300
Overall length with coupling	L2	mm	437
Length of calculator	L1	mm	117
Height	H	mm	51
Height	H1	mm	89
Height of calculator	H2	mm	39
Height of calculator	H3	mm	44
Width	B	mm	97
Width of calculator	B1	mm	81
Connection thread of meter	AGZ	Inch	G2B
Connection thread of coupling	AGV	Inch	G1½B
Weight		kg	7.2

**Dimensions,
DN20, DN25, DN40,
DN50 flange**

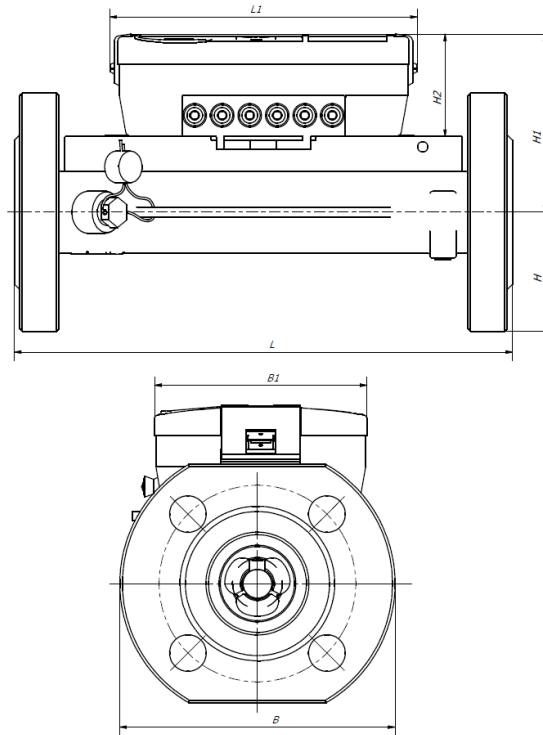

Nominal flow rate	q _p	m ³ /h	0.6/1/1.5/2.5	3.5/6	10	15
Nominal diameter	DN	mm	20	25	40	50
Overall length	L	mm	190	260	300	270
Length of calculator	L1	mm	117	117	117	117
Height	H	mm	46	58	73	79
Height	H1	mm	68	78	91	90
Height of calculator	H2	mm	39	39	39	39
Width	B	mm	105	116	150	159
Width of calculator	B1	mm	81	81	81	81
Connection flange of meter	DN _{FL}	mm	20	25	40	50
Weight		kg	2.5	5.6	6.8	8.5

Danfoss A/S

Energy Meters • Ulvehavevej 61 • DK-7100 Vejle • Denmark

Phone: +45 7488 8500 • Fax: +45 7488 8501

heating@danfoss.com • www.heating.danfoss.com

Danfoss can accept no responsibility for possible errors in catalogues, brochures and other printed material. Danfoss reserves the right to alter its products without notice. This also applies to products already on order provided that such alterations can be made without subsequential changes being necessary in specifications already agreed. All trademarks in this material are property of the respective companies. Danfoss and the Danfoss logotype are trademarks of Danfoss A/S. All rights reserved.